

Keysight Add 4-Port Capability Upgrade Kit

To Upgrade PNA-X N5241A, N5242A or N5249A Option 200 to Option 400

For Analyzers with Serial Numbers Prefixed MY/SG/US5150 and Below

Upgrade Kit Order Number: N5241AU- 940, N5242AU- 940 and N5249AU- 940

Keysight Kit Number: N5242-60107

Notices

© Keysight Technologies, Inc.
2009-2015

No part of this manual may be reproduced in any form or by any means (including electronic storage and retrieval or translation into a foreign language) without prior agreement and written consent from Keysight Technologies, Inc. as governed by United States and international copyright laws.

Trademark Acknowledgments

Manual Part Number

N5242-90015

Edition

June 2015

Printed in USA/Malaysia

Published by:
Keysight Technologies
1400 Fountaingrove Parkway
Santa Rosa, CA 95403

Warranty

THE MATERIAL CONTAINED IN THIS DOCUMENT IS PROVIDED "AS IS," AND IS SUBJECT TO BEING CHANGED, WITHOUT NOTICE, IN FUTURE EDITIONS. FURTHER, TO THE MAXIMUM EXTENT PERMITTED BY APPLICABLE LAW, KEYSIGHT DISCLAIMS ALL WARRANTIES, EITHER EXPRESS OR IMPLIED WITH REGARD TO THIS MANUAL AND ANY INFORMATION CONTAINED HEREIN, INCLUDING BUT NOT LIMITED TO THE IMPLIED WARRANTIES OF MERCHANTABILITY AND FITNESS FOR A PARTICULAR PURPOSE. KEYSIGHT SHALL NOT BE LIABLE FOR ERRORS OR FOR INCIDENTAL OR CONSEQUENTIAL DAMAGES IN CONNECTION WITH THE FURNISHING, USE, OR PERFORMANCE OF THIS DOCUMENT OR ANY INFORMATION CONTAINED HEREIN. SHOULD KEYSIGHT AND THE USER HAVE A SEPARATE WRITTEN AGREEMENT WITH WARRANTY TERMS COVERING THE MATERIAL IN THIS

DOCUMENT THAT CONFLICT WITH THESE TERMS, THE WARRANTY TERMS IN THE SEPARATE AGREEMENT WILL CONTROL.

Technology Licenses

The hardware and/or software described in this document are furnished under a license and may be used or copied only in accordance with the terms of such license.

U.S. Government Rights

The Software is "commercial computer software," as defined by Federal Acquisition Regulation ("FAR") 2.101. Pursuant to FAR 12.212 and 27.405-3 and Department of Defense FAR Supplement ("DFARS") 227.7202, the U.S. government acquires commercial computer software under the same terms by which the software is customarily provided to the public.

Accordingly, Keysight provides the Software to U.S. government customers under its standard commercial license, which is embodied in its End User License Agreement (EULA), a copy of which can be found at

<http://www.keysight.com/find/sweula>

The license set forth in the EULA represents the exclusive authority by which the U.S. government may use, modify, distribute, or disclose the Software. The EULA and the license set forth therein, does not require or permit, among other things, that Keysight: (1) Furnish technical information related to commercial computer software or commercial computer software documentation that is not customarily provided to the public; or (2) Relinquish to, or otherwise provide, the government rights in excess of these rights customarily provided to the public to use, modify, reproduce, release, perform, display, or disclose commercial computer software or commercial computer software documentation. No additional

government requirements beyond those set forth in the EULA shall apply, except to the extent that those terms, rights, or licenses are explicitly required from all providers of commercial computer software pursuant to the FAR and the DFARS and are set forth specifically in writing elsewhere in the EULA. Keysight shall be under no obligation to update, revise or otherwise modify the Software. With respect to any technical data as defined by FAR 2.101, pursuant to FAR 12.211 and 27.404.2 and DFARS 227.7102, the U.S. government acquires no greater than Limited Rights as defined in FAR 27.401 or DFAR 227.7103-5 (c), as applicable in any technical data.

Safety Notices

CAUTION

A **CAUTION** notice denotes a hazard. It calls attention to an operating procedure, practice, or the like that, if not correctly performed or adhered to, could result in damage to the product or loss of important data. Do not proceed beyond a CAUTION notice until the indicated conditions are fully understood and met.

WARNING

A **WARNING** notice denotes a hazard. It calls attention to an operating procedure, practice, or the like that, if not correctly performed or adhered to, could result in personal injury or death. Do not proceed beyond a WARNING notice until the indicated conditions are fully understood and met.

Keysight Add 4-Port Capability Upgrade Kit
Upgrade Kit Order Number: N5241AU- 940, N5242AU- 940 and
N5249AU- 940
Installation Note

Description of the Upgrade

NOTE

This upgrade kit is only for analyzers with serial numbers prefixed MY/SG/US5150 and below. If the serial number prefix of your analyzer is above this number, do NOT proceed with the upgrade. Analyzers with serial numbers prefixed MY/SG/US5150 and below were manufactured prior to February 2012, and have a older chassis style that requires older synthesizer boards (included in this kit) without screw tabs. For more information on part numbers, refer to Chapter 6 in the Service Guide. See [“Downloading the Online PNA Service Guide” on page 6.](#)

NOTE

In June 2013, the N5241A/AS and N5242A/AS analyzers underwent significant hardware changes. Some components that have 2.4 mm connectors (bias tees, couplers, and some semi-rigid cables) were replaced with components that have 3.5 mm connectors. Your analyzer was originally shipped with 2.4 mm components. The 2.4 mm couplers and connecting cables in your analyzer must be replaced with the new 3.5 mm items included in this kit.

This upgrade converts your N5241A or N5242A Option 200 2-port analyzer to a N5241A or N5242A Option 400 4-port analyzer by adding:

- an additional 26.5 GHz source board
- an additional 13.5 GHz source synthesizer board
- an additional mixer brick
- two additional bridges
- four couplers
- a splitter
- a modified front panel, including 2 new test ports
- many new cables

Getting Assistance from Keysight

Installing this upgrade kit requires special skills and experience. If you think you may not be qualified to do the work, or need advice, contact Keysight.

Contacting Keysight

Assistance with test and measurements needs and information on finding a local Keysight office are available on the Web at:

<http://www.keysight.com/find/assist>

If you do not have access to the Internet, please contact your Keysight field engineer.

NOTE

In any correspondence or telephone conversation, refer to the Keysight product by its model number and full serial number. With this information, the Keysight representative can determine whether your product is still within its warranty period.

If You Have Problems With the Upgrade Kit Contents

Keysight stands behind the quality of the upgrade kit contents. If you have problems with any item in the kit, email Keysight Component Test Division (CTD) Support at support_ctd-soco@keysight.com, or telephone the CTD Hotline at (707) 577-6802 and leave a voice mail message. Please include details of the problem.

Getting Prepared

CAUTION

The PNA contains extremely sensitive components that can be ruined if mishandled. Follow instructions carefully when making cable connections, especially wire harness connections.

The person performing the work accepts responsibility for the full cost of the repair or replacement of damaged components.

To successfully install this upgrade kit, you will need the following:

- A PDF copy or a paper copy of the PNA Service Guide - refer to **“Downloading the Online PNA Service Guide”** below.
- An ESD-safe work area - refer to **“Protecting Your Workspace from Electrostatic Discharge”** below.
- Correct tools - refer to **“Tools Required for the Installation”** on page 7.
- Enough time - refer to **“About Installing the Upgrade”** on page 7.
- Test equipment for the post-upgrade adjustments. To view the equipment list, click the Chapter 3 bookmark "Tests and Adjustments" in the PDF Service Guide¹.

License Key Redemption

NOTE

The enclosed Option Entitlement Certificate is a receipt, verifying that you have purchased a licensed option for the PNA of your choice. You must now use a Keysight Web page to request a license key for the instrument that will receive the option.

To enable the option product, you must request a license key from: <http://www.keysight.com/find/softwarelicense>. To complete the request, you will need to gather the following information:

- From the certificate
 - Order number
 - Certificate number
- From your instrument
 - Model number
 - Serial number
 - Host ID

The instrument information is available on the network analyzer – on the analyzer’s Help menu, click About Network Analyzer.

1. See **“Downloading the Online PNA Service Guide”** on page 6.

Description of the Upgrade Getting Prepared

If you provide an email address, Keysight will promptly email your license key. Otherwise, you will receive your license key via postal mail.

Downloading the Online PNA Service Guide

To view the online Service Guide for your PNA model number, use the following steps:

1. Go to www.keysight.com.
2. In the Search box, enter the model number of the analyzer (Ex: N5242A) and click **Search**.
3. Click **Technical Support > Manuals**.
4. Click **Service Manual**.
5. Click the service guide title to download the PDF file.
6. When the PDF of the Service Guide is displayed, scroll through the Contents section bookmarks to locate the information needed.

Protecting Your Workspace from Electrostatic Discharge

For information, click on the Chapter 1 bookmark, “Electrostatic Discharge Protection” in the PDF Service Guide¹.

ESD Equipment Required for the Installation

Description	Keysight Part Number
ESD grounding wrist strap	9300-1367
5-ft grounding cord for wrist strap	9300-0980
2 x 4 ft conductive table mat and 15-ft grounding wire	9300-0797
ESD heel strap (for use with conductive floors)	9300-1308

Description of the Upgrade
Getting Prepared

Tools Required for the Installation

Description	Qty	Part Number
T-10 TORX driver - set to 9 in-lbs (1.02 N.m)	1	N/A
T-20 TORX driver - set to 21 in-lbs (2.38 N.m)	1	N/A
5/16-in (8 mm) nutsetter or open end torque wrench - set to 10 in-lbs (1.13 N.m)	1	N/A
5/16-in (8 mm) nutsetter or open end torque wrench - set to 21 in-lbs (2.38 N.m)	1	N/A
3/16-in (5 mm) nutsetter or open end torque wrench - set to 6 in-lbs (0.68 N.m)	1	N/A
5/8-in (16 mm) nutsetter or open end torque wrench - set to 21 in-lbs (2.38 N.m)	1	N/A
1-in (25.4 mm) torque wrench - set to 72 in-lbs (8.15 N.m)	1	N/A
1/4-in (6 mm) open end wrench	1	N/A

CAUTION

Use a 5/16-in torque wrench set to 10 in-lbs on all cable connections except the front and rear panel bulkhead connectors. Torque these connections to 21 in-lb.

About Installing the Upgrade

Products affected	N5241A, N5242A and N5249A Option 200
Installation to be performed by	Keysight service center or personnel qualified by Keysight
Estimated installation time	4 hours
Estimated adjustment time	1 hours
Estimated full instrument calibration time	4.5 hours

Items Included in the Upgrade Kit

Check the contents of your kit against the following list. If any part is missing or damaged, contact Keysight Technologies. Refer to **“Getting Assistance from Keysight” on page 4.**

Table 1 Contents of Upgrade Kit N5242-60107

Ref Desig.	Description	Qty	Part Number
-	Installation note (this document)	1	N5242-90015
A8	26.5 GHz source (2) board	1	5087-7837 Was 5087-7307
A13	13.5 GHz source 2 synthesizer board ^a	3	N5240-60076 Was N5242-60166
A22	Splitter	1	5087-7139
A24	Mixer brick (2)	1	5087-7829 Was 5087-7766, or 5087-7722
A26	Test port 3 bridge	2	5087-7757 Was 5087-7315
A27	Test port 4 bridge		
A29	Test port 1 coupler	4	5087-7813
A30	Test port 3 coupler		
A31	Test port 4 coupler		
A32	Test port 2 coupler		
-	Machine screw, M3.0 x 6, flat head (to attach lower front dress panel to the test set front plate)	4	0515-1227
-	Machine screw, M3.0 x 20, pan head (3 to attach mixer brick 2 to mounting block; 4 to attach 2 bridges to brackets)	7	0515-1410
-	Machine screw, M3.0 x 8, pan head (2 to attach mixer brick 2 to mounting block)	4	0515-0372
-	Machine screw, M3.0 x 6, pan head (4 to attach 2 bridges to deck)	4	0515-0430
-	Machine screw, M3.0 x 14, pan head (2 to attach splitter to mixer brick mounting block)	2	0515-2994 Was 0515-0665
-	Machine screw, M4 x 10, pan head (to attach A8 source 2 assy. to A19 motherboard)	2	0515-0380
--	Bulkhead connector assembly for test set front plate	16	1250-3805
-	Front panel overlay (label), 4-port	1	N5222-80006 Was N5242-80003
-	Keypad overlay (label)	1	N5242-80005

Description of the Upgrade
Items Included in the Upgrade Kit

Table 1 Contents of Upgrade Kit N5242-60107

Ref Desig.	Description	Qty	Part Number
-	Power switch overlay (label)	1	N5242-80007
-	Test set front plate, 4-port	1	N5221-00007
-	Gap pad (between each coupler and test set front plate)	4	E4403-20033
-	Vibration mount (between couplers 1 & 3, and 2 & 4)	2	0460-2725
-	Mounting nuts (for ports 3 & 4 test port couplers)	2	5022-1087
-	Short (for Mixer Brick A24)	1	0960-0055
-	Front frame, 1-piece, machined, 4-port	1	N5247-20141 Was N5245-20128
-	Bracket for test port bridge	2	N5242-00006
-	Cable guard	1	N5242-00030
-	Nameplate, N5241A	1	N5241-80001
-	Nameplate, N5242A	1	N5242-80006
-	Dust caps for test ports	4	1401-0214
-	Tie wrap, to secure cables to side of deck	8	1400-0249
W2	A13 13.5 GHz (source 2) synth board J1207 to A8 26.5 GHz source (2) board P1	1	N5222-20090
W5	A8 source (2) to W6	1	N5222-20062
W6	W5 to A26 port 3 bridge	1	N5222-20041
W7	A8 source (2) to W8	1	N5222-20063
W8	W7 to A27 port 4 bridge	1	N5222-20042
W12	A29 port 1 coupler to front-panel Port 1 CPLR THRU	1	N5222-20045
W14	A29 port 1 coupler to front-panel Port 1 CPLR ARM	1	N5222-20030
W15	A26 port 3 bridge to front-panel Port 3 SOURCE OUT	1	N5222-20047
W16	A30 port 3 coupler to front-panel Port 3 CPLR THRU	1	N5222-20049
W17	A26 port 3 bridge to front-panel REF 3 SOURCE OUT	1	N5222-20023
W18	A30 port 3 coupler to front-panel Port 3 CPLR ARM	1	N5222-20015
W19	A27 port 4 bridge to front-panel Port 4 SOURCE OUT	1	N5222-20050
W20	A31 port 4 coupler to front-panel Port 4 CPLR THRU	1	N5222-20054
W21	A27 port 4 bridge to front-panel REF 4 SOURCE OUT	1	N5222-20025
W22	A31 port 4 coupler to front-panel Port 4 CPLR ARM	1	N5222-20018
W24	A32 port 2 coupler to front-panel Port 2 CPLR THRU	1	N5222-20053
W26	A32 port 2 coupler to front-panel Port 2 CPLR ARM	1	N5222-20034
W30	Front panel jumpers	6	N5222-20091

Description of the Upgrade
Items Included in the Upgrade Kit

Table 1 Contents of Upgrade Kit N5242-60107

Ref Desig.	Description	Qty	Part Number
W32	Front panel port 3 RCVR C IN to A24 mixer brick (C)	1	N5222-20048
W33	Front panel port 4 RCVR D IN to A24 mixer brick (D)	1	N5222-20055
W42	A21 HMA26.5 to A22 splitter	1	N5222-20009
W43	A22 splitter to A23 mixer brick	1	N5222-20007
W44	A22 splitter to A24 mixer brick	1	N5222-20008
W49	Front panel REF 3 RCVR R3 IN to A24 mixer brick (R3)	1	N5222-20057
W50	Front panel REF 4 RCVR R4 IN to A24 mixer brick (R4)	1	N5222-20058
W52	A23 mixer brick (R1) to A20 IF multiplexer (P411)	1	N5242-60021
W53	A23 mixer brick (R2) to A20 IF multiplexer (P412)	1	N5242-60022
W55	A24 mixer brick (D) to A20 IF multiplexer (P801)	1	N5242-60024
W56	A24 mixer brick (R4) to A20 IF multiplexer (P414)	1	N5242-60019
W57	A24 mixer brick (R3) to A20 IF multiplexer (P413)	1	N5242-60020
W58	A24 mixer brick (C) to A20 IF multiplexer (P601)	1	N5242-60023
W58	A24 mixer brick (C) to A20 IF multiplexer (P601)	1	N5242-60023
W60	A20 IF multiplexer (P203) to A12 SPAM (J2)	1	N5242-60013
W62	A20 IF multiplexer (P603) to A12 SPAM (J5)	1	N5242-60015
W67	A10 frequency reference board J7 to A13 13.5 GHz (source 2) synth board J5	1	N5242-60030
-	Ribbon cable, A19 test set motherboard J213 to A24 mixer brick (2)	1	N5242-60006

- a. The three 13.5 GHz Synthesizer boards included in this kit are the RoHS compliant N5240-60076 boards. These new boards are not compatible with the old N5230-60002 13.5 GHz Synthesizer boards. If the boards installed in your PNA are the old N5230-60002, you must replace ALL of them with the N5240-60076 boards included in this kit - refer to your PNA Service Guide's chapter 7 for instructions. If your PNA already contains the new boards, scrap the two extra N5240-60076 boards included in this kit.

For the new N5240-60076 boards to function properly in your PNA, you must upgrade your PNA firmware to rev A09.33xx or above. Download PNA firmware at: <http://na.support.keysight.com/pna/firmware/firmware.html>.

NOTE

Extra quantities of items such as protective plastic caps, screws, cable ties, and cable clamps may be included in this upgrade kit. It is normal for some of these items to remain unused after the upgrade is completed.

Installation Procedure for the Upgrade

The network analyzer must be in proper working condition prior to installing this option. Any necessary repairs must be made before proceeding with this installation.

WARNING

This installation requires the removal of the analyzer's protective outer covers. The analyzer must be powered down and disconnected from the mains supply before performing this procedure.

Overview of the Installation Procedure

- “Step 1. Obtain a Keyword and Verify the Information.”
- “Step 2. Remove the Outer Cover.”
- “Step 3. Remove the Inner Cover.”
- “Step 4. Remove the Front Panel Assembly.”
- “Step 5. Remove the A19 Test Set Motherboard.”
- “Step 6. Remove Some Existing Test Set Cables.”
- “Step 7. Remove the A23 Mixer Brick Assembly.”
- “Step 8. Assemble the A24 Mixer Brick and A22 Splitter.”
- “Step 9. Assemble the A26 and A27 Test Port Bridges.”
- “Step 10. Install the Mixer Bricks Assembly and Test Port Bridge Assemblies.”
- “Step 11. Assemble the A29 - A32 Test Port Coupler Assemblies.”
- “Step 12. Install the LED Boards and Test Port Coupler Assemblies to the Test Set Front Plate.”
- “Step 13. Install the Bulkhead Connectors in the Test Set Front Plate.”
- “Step 14. Install the Coupler Plate Assembly to the Deck.”
- “Step 15. Install the Second Source Boards.”
- “Step 16. Install the Semirigid Test Set Cables.”
- “Step 17. Reinstall the A19 Test Set Motherboard.”
- “Step 18. Disassemble the 2-Port Front Panel and Assemble the 4-Port Front Panel.”
- “Step 19. Reinstall the Front Panel Assembly.”
- “Step 20. Install the Front Panel Overlays.”
- “Step 21. Install the Front Panel Jumper Cables.”
- “Step 22. Position the Cables and Wires to Prevent Pinching.”

Description of the Upgrade
Installation Procedure for the Upgrade

“Step 23. Reinstall the Inner Cover.”

“Step 24. Reinstall the Outer Cover.”

“Step 25. Enable Option 400.”

“Step 26. Perform Post-Upgrade Adjustments and Calibration.”

“Step 27. Prepare the PNA for the User.”

Step 1. Obtain a Keyword and Verify the Information

Follow the instructions on the Option Entitlement Certificate supplied to obtain a license key for installation of this upgrade. Refer to **“License Key Redemption” on page 5.**

Verify that the model number, serial number, and option number information on the license key match those of the instrument on which this upgrade will be installed.

If the model number, serial number, or option number do not match those on your license key, you will not be able to install the option. If this is the case, contact Keysight for assistance before beginning the installation of this upgrade. Refer to **“Contacting Keysight” on page 4.**

Once the license key has been received and the information verified, you can proceed with the installation at step 2.

Step 2. Remove the Outer Cover

For instructions, click the Chapter 7 bookmark "Removing the Covers" in the PDF Service Guide¹.

Step 3. Remove the Inner Cover

For instructions, click the Chapter 7 bookmark “Removing the Covers” in the PDF Service Guide¹.

Step 4. Remove the Front Panel Assembly

For instructions, click the Chapter 7 bookmark “Removing and Replacing the Front Panel Assembly” in the PDF Service Guide¹.

Step 5. Remove the A19 Test Set Motherboard

For instructions, click the Chapter 7 bookmark “Removing and Replacing the A19 Test Set Motherboard” in the PDF Service Guide¹.

1. See **“Downloading the Online PNA Service Guide” on page 6.**

Step 6. Remove Some Existing Test Set Cables

NOTE

Leave the gray flexible cables, the wire harnesses, and the ribbon cables connected where possible. Any that are removed should be labeled for reconnection later.

CAUTION

Be careful not to damage the center pins of the semirigid cables. Some flexing of the cables may be necessary but do not over-bend them.

1. Place the analyzer bottom-side up on a flat surface.
2. Remove and discard the following gray flexible cables:
 - W150 A20 IF multiplexer (P203) to A12 SPAM (J5)
 - W140 A20 IF multiplexer (P603) to A12 SPAM (J2)
3. Remove all bottom-side semirigid cables except for those in the table below. To see an image showing the location of these cables, click the Chapter 6 bookmark "Bottom RF Cables, Standard 2-Port Configuration, Option 200" in the PDF Service Guide¹. Do not discard the cables because some will be reused later in the procedure.

Reference Designator	Type ^a	Qty	Description
W3	SR	1	A5 source (1) to W4
W9	SR	1	A5 source (1) to W10
W45	SR	1	A5 source (1) to W46
W46	SR	1	W46 to rear-panel EXT TSET DRIVE RF OUT (J6)
W47	SR	1	A23 mixer brick to EXT TSET DRIVE LO OUT (J5)

a. SR = semirigid coaxial cable.

4. Leave the gray flexible cables, the wire harnesses, and the ribbon cables connected where possible. Any that are removed should be labeled for reconnection later.

Step 7. Remove the A23 Mixer Brick Assembly

Remove the A23 mixer brick assembly from the PNA. For instructions, click the Chapter 7 bookmark, "Removing and Replacing the A23 and A24 Mixer Bricks" in the PDF Service Guide¹.

1. See ["Downloading the Online PNA Service Guide" on page 6](#).

Step 8. Assemble the A24 Mixer Brick and A22 Splitter

Refer to **Figure 2** in this document for this step. New parts are listed in **Table 1 on page 8** of this document.

1. Install the A24 mixer brick (5087-7829) to the mounting block by hand-starting three screws (item ①; 0515-1410). Do not tighten.
2. Install two screws (item ②; 0515-0372) and torque to 9 in-lbs.
3. Go back and torque the three screws (item ①; 0515-1410) to 9 in-lbs.

Figure 2

A24 Mixer Brick Assembly

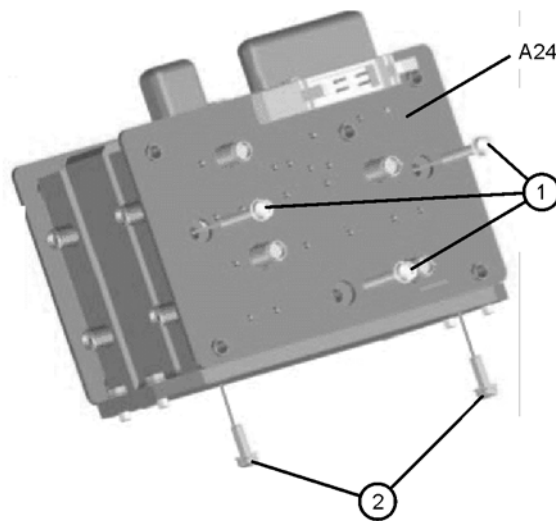

N5242_015_05

Refer to **Figure 3** in this document for the remainder of this step.

4. Follow the eleven instructions shown in **Figure 3**. New parts are listed in **Table 1 on page 8** of this document.

NOTE

Graphics in this document such as **Figure 3** use very brief text to instruct where to connect a cable. For example, text that reads “N5242-60018 IFMUX P201 - BRK1 B” means to connect the N5242-60018 gray flexible cable at the A20 IF MUX board connector P201 and at A23 Mixer Brick 1 connector B.

Figure 3 A23 and A24 Mixer Brick Assembly

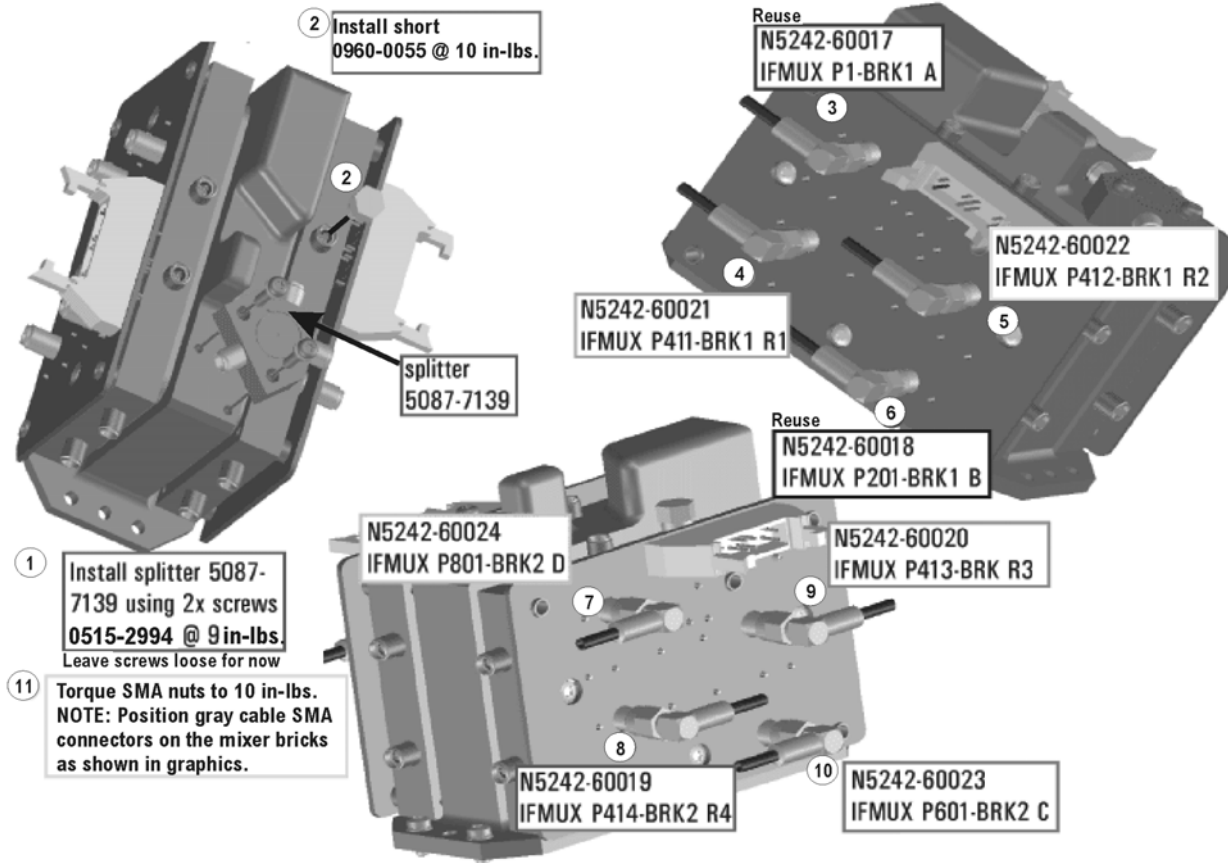

N5242_015_06

Step 9. Assemble the A26 and A27 Test Port Bridges

Follow the two instructions shown in **Figure 4** in this document. New parts are listed in **Table 1 on page 8** of this document.

Figure 4 A26 and A27 Test Port Bridge Assembly

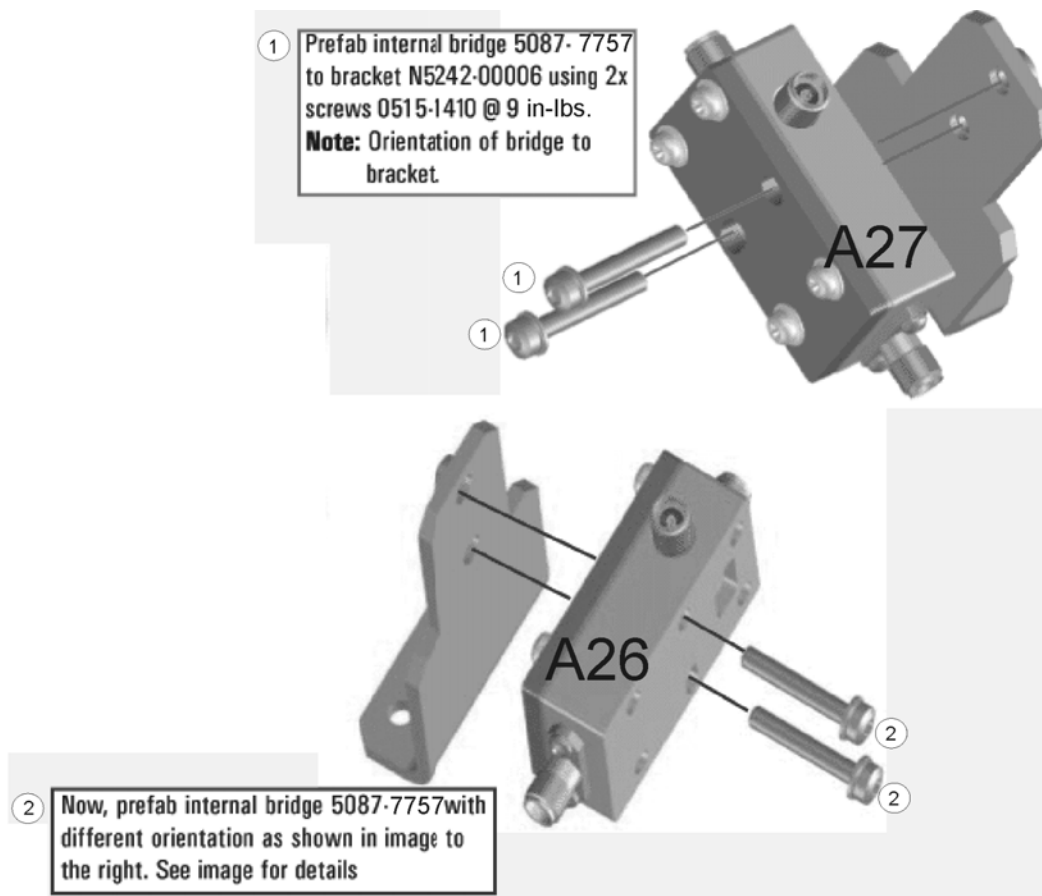

N5242_015_07

Step 10. Install the Mixer Bricks Assembly and Test Port Bridge Assemblies

Follow the two instructions shown in **Figure 5** in this document. New parts are listed in **Table 1 on page 8** of this document.

Figure 5 A23, A24 Mixer Bricks Installation and A26, A27 Test Port Bridges Installation

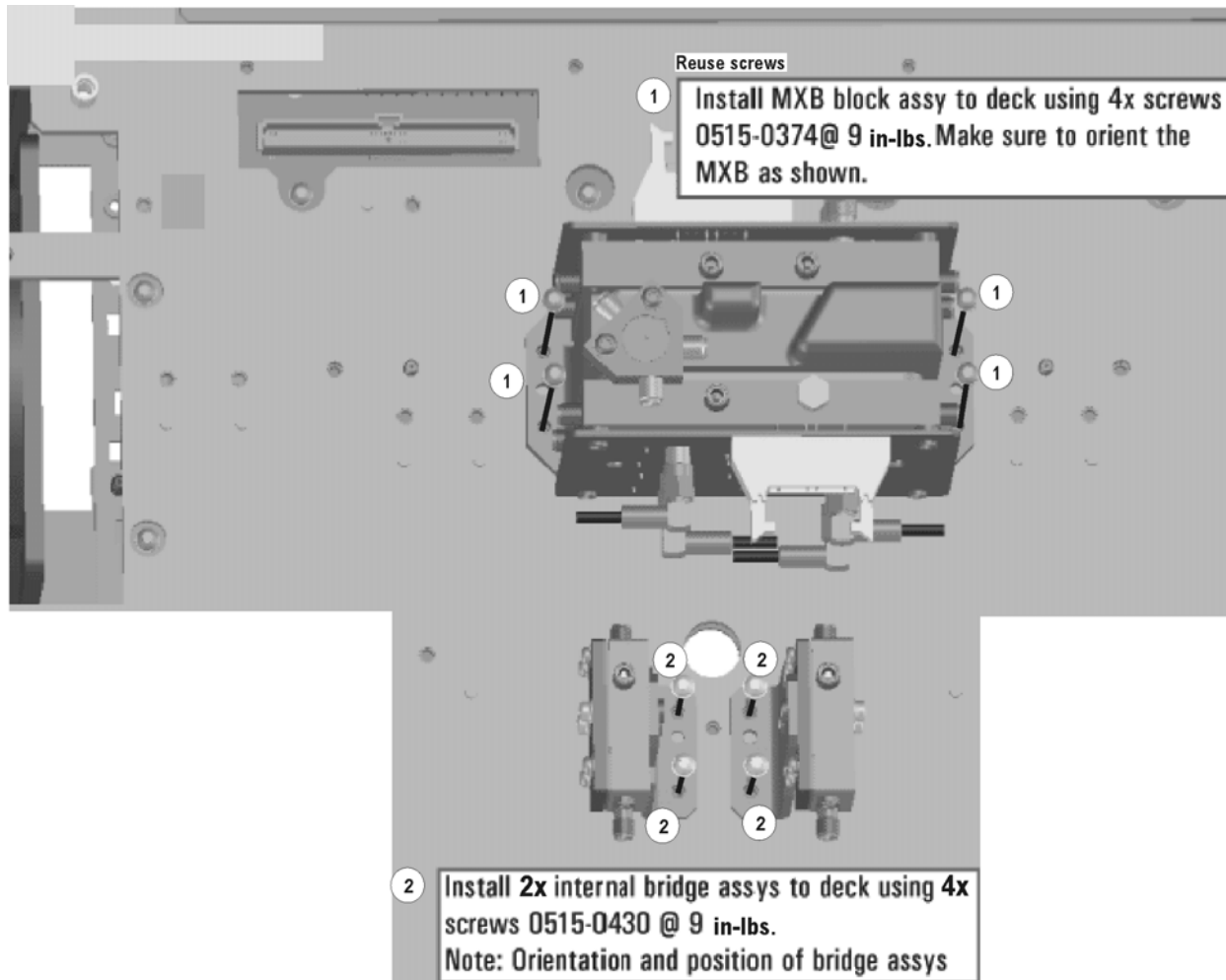

N5242_015_08

Step 11. Assemble the A29 - A32 Test Port Coupler Assemblies

1. Remove the A29 test port 1 coupler and A32 test port 2 coupler from the PNA. For instructions, click the Chapter 7 bookmark, "Removing and Replacing the A29 - A32 Test Port Couplers" in the PDF Service Guide¹.
2. Discard the test port couplers you just removed from the PNA. These old couplers have 2.4 mm connectors and must be replaced with the new couplers (3.5 mm connectors) included in the kit.
3. Follow the two instructions shown in **Figure 6**. New parts are listed in **Table 1 on page 8** of this document.

Figure 6 A29 - A32 Test Port Coupler Assembly

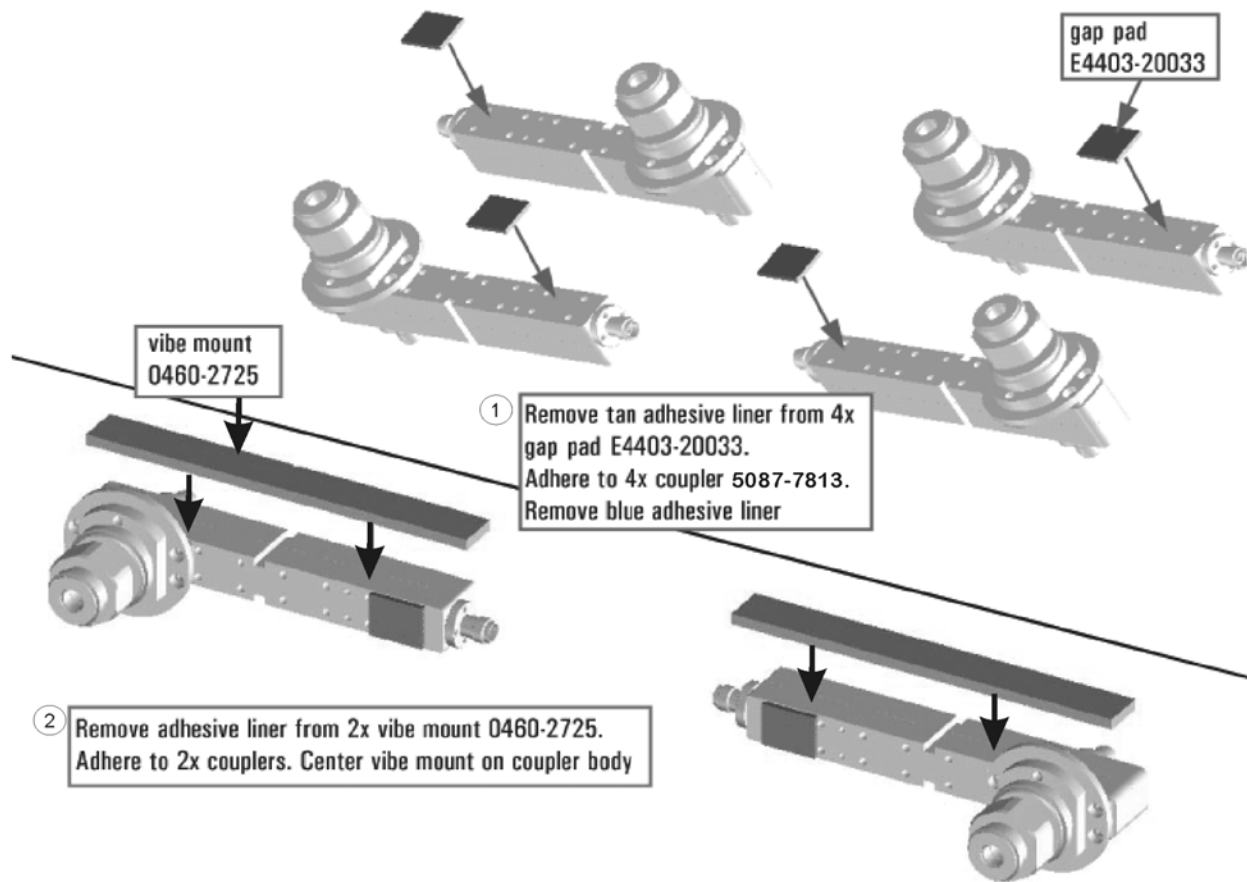

N5242_015_11

1. See ["Downloading the Online PNA Service Guide"](#) on page 6.

Step 12. Install the LED Boards and Test Port Coupler Assemblies to the Test Set Front Plate

1. Remove two screws from each LED board and remove the boards from the 2-port test set front plate of the PNA.
2. Remove the 2-port test set front plate from the test set deck.
3. Follow the two instructions shown in [Figure 7](#) of this document. New parts are listed in [Table 1 on page 8](#) of this document.

Figure 7 LED Board Assemblies and Test Port Coupler Assemblies Installation

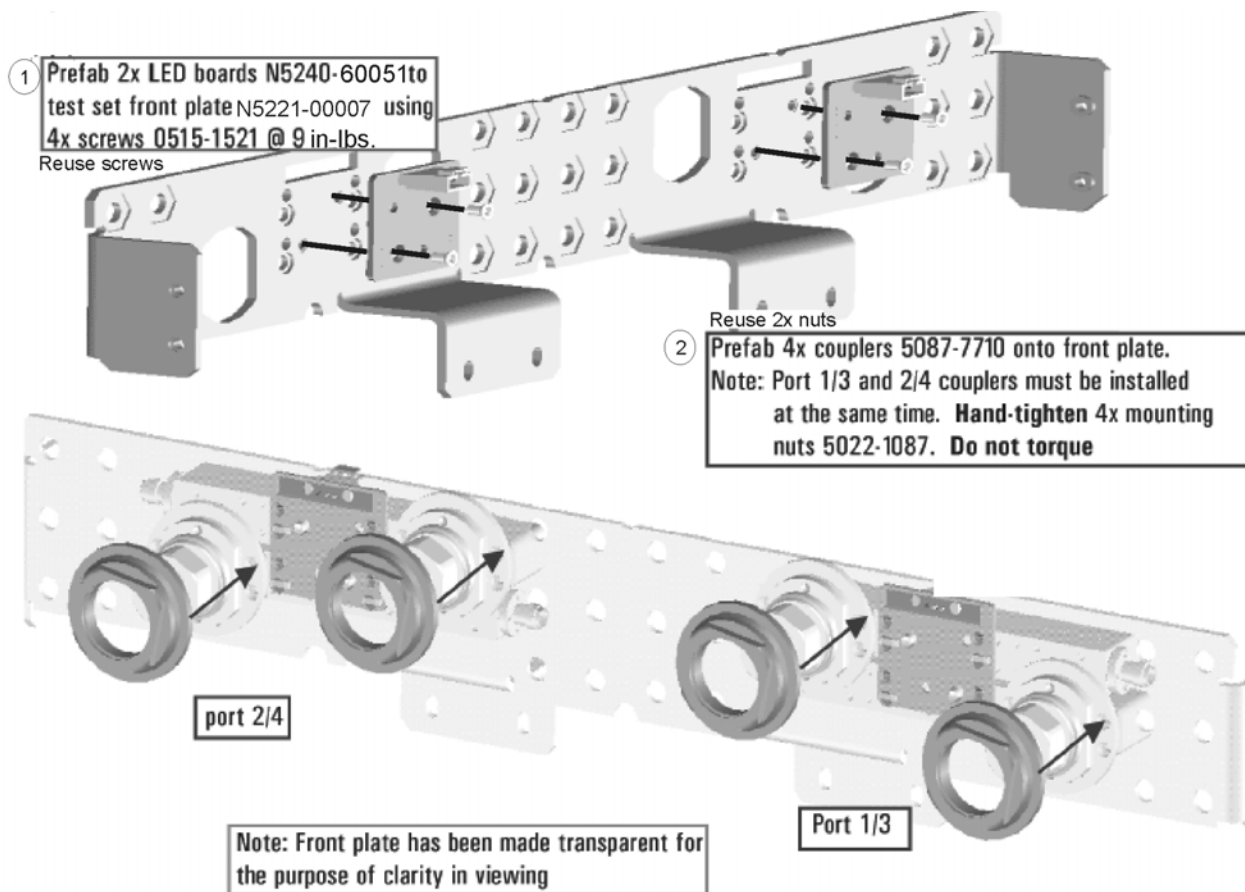

N5242_015_1

Step 13. Install the Bulkhead Connectors in the Test Set Front Plate

Refer to **Figure 8** for this procedure. New parts are listed in **Table 1 on page 8**.

1. From the back side of the test set front plate, insert a bulkhead connector into a hole in the plate.
2. Install 1x washer and 1x nut. Hand tighten nut and ensure bulkhead connector hexagon nut, on the back side of test set front plate, is aligned to the test set subpanel hexagon indent.
3. Repeat previous two steps for the remaining bulkhead connectors.
4. Torque nuts, on the front side of test set front plate, to 21 in-lbs.

Figure 8

Bulkhead Connectors Installation

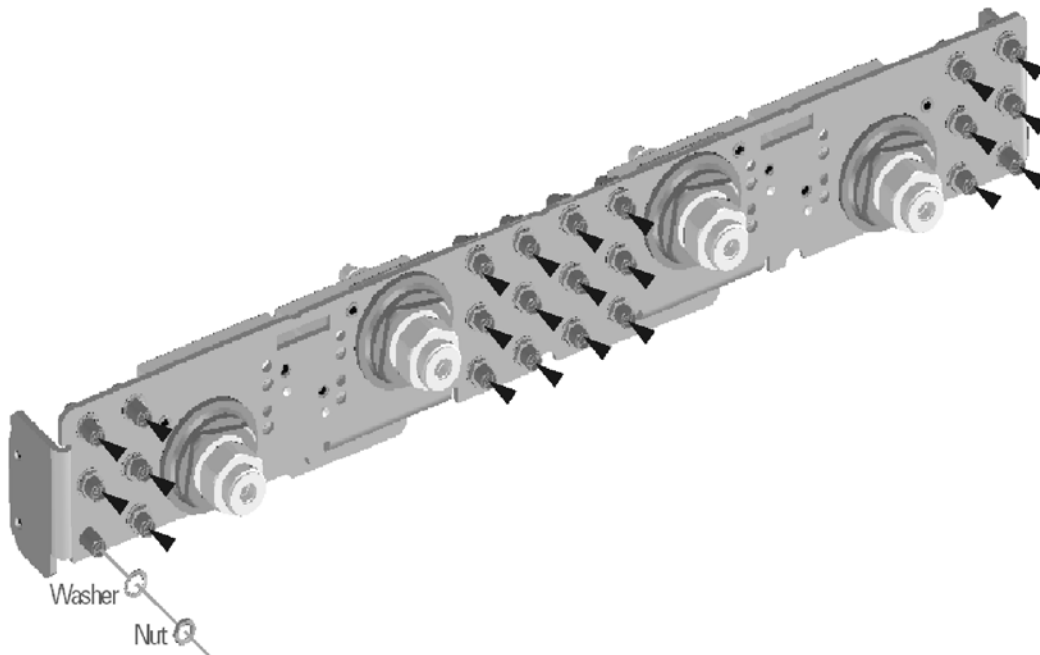

N5242_004_09

Step 14. Install the Coupler Plate Assembly to the Deck

Follow the four instructions shown in **Figure 9**.

Figure 9 Coupler Plate Assembly Installation

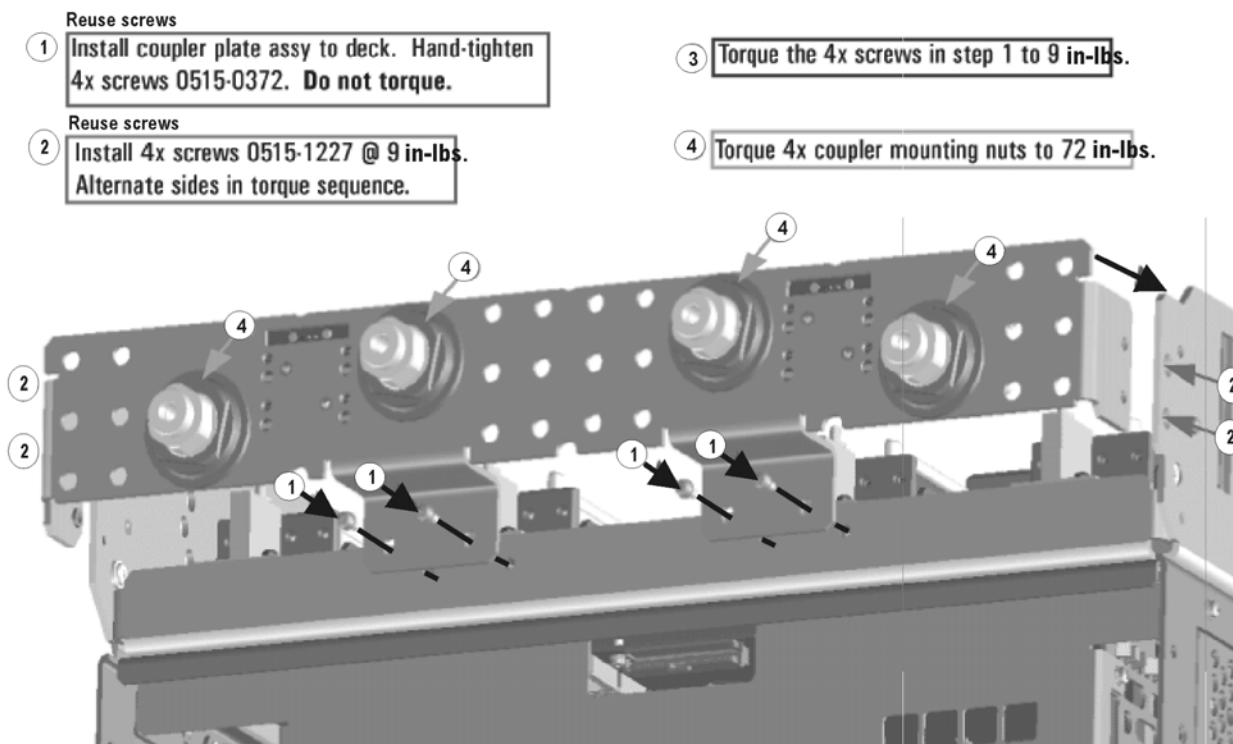

N5242_015_13

Step 15. Install the Second Source Boards

Install Cables on Source 2 Board

Refer to **Figure 10** of this document for this part of this step. New parts are listed in **Table 1 on page 8** of this document.

1. Attach new cables W5 (N5222-20062) and W7 (N5222-20063) to the A8 26.5 GHz source 2 board as shown. Make sure that both cables are parallel to the A8 26.5 GHz source board as shown in the END VIEW. Cable W5 is the longer of the two cables.
2. Use a 5/16-in torque wrench set to 10 in-lbs to tighten the cable connectors.

Figure 10 Second Source Boards Installation, Part 1

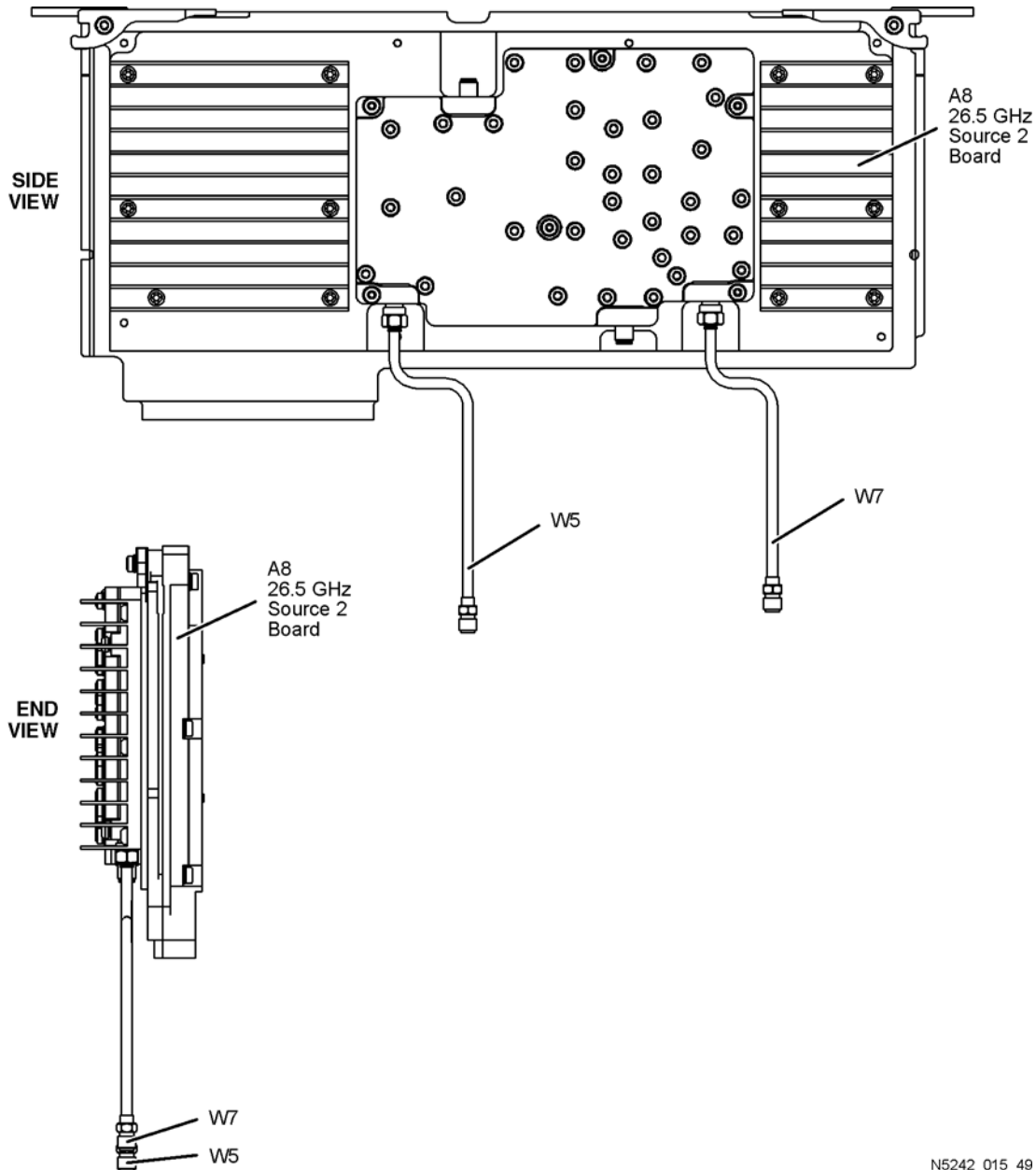

Install Cable on Source 2 Synthesizer Board

Install gray cable W67 (N5242-60030) to connector J5 of the Source 2 Synthesizer board. The loose end of the cable will be connected on the A10 frequency reference board (J7) after the Source 2 Synthesizer board has been installed in the analyzer.

Install the Second Source Boards into the Analyzer

Refer to **Figure 11** for this part of this step of the procedure. New parts are listed in **Table 1 on page 8**.

1. Install the A8 26.5 GHz source 2 board (5087-7837) and the A13 13.5 GHz source 2 synthesizer board (N5230-60002) in the analyzer as shown. Secure the A8 26.5 GHz source 2 board with two screws (item ①; 0515-0380) and torque to 21 in-lbs.
2. Connect cable W2 (N5222-20090) between the A8 26.5 GHz source 2 board and the A13 13.5 GHz source 2 synthesizer board as shown. Be sure to position the cable in the wire looms as shown. Tighten the cable connectors to 10 in-lbs using a 5/16-in torque wrench.
3. Connect the loose end of new gray flex cable W22 (N5242-60030) on the A10 frequency reference board (J7). (The other end of this cable was previously connected to J5 of the source 2 synthesizer board.)

NOTE

The three 13.5 GHz Synthesizer boards included in this kit are the RoHS compliant N5240-60076 boards. These new boards are not compatible with the old N5230-60002 13.5 GHz Synthesizer boards. If the boards installed in your PNA are the old N5230-60002, you must replace ALL of them with the N5240-60076 boards included in this kit - refer to your PNA Service Guide's chapter 7 for instructions. If your PNA already contains the new boards, scrap the two extra N5240-60076 boards included in this kit.

For the new N5240-60076 boards to function properly in your PNA, you must upgrade your PNA firmware to rev A09.33xx or above. Download PNA firmware at:

<http://na.support.keysight.com/pna/firmware/firmware.html>

Figure 11

Second Source Boards Installation

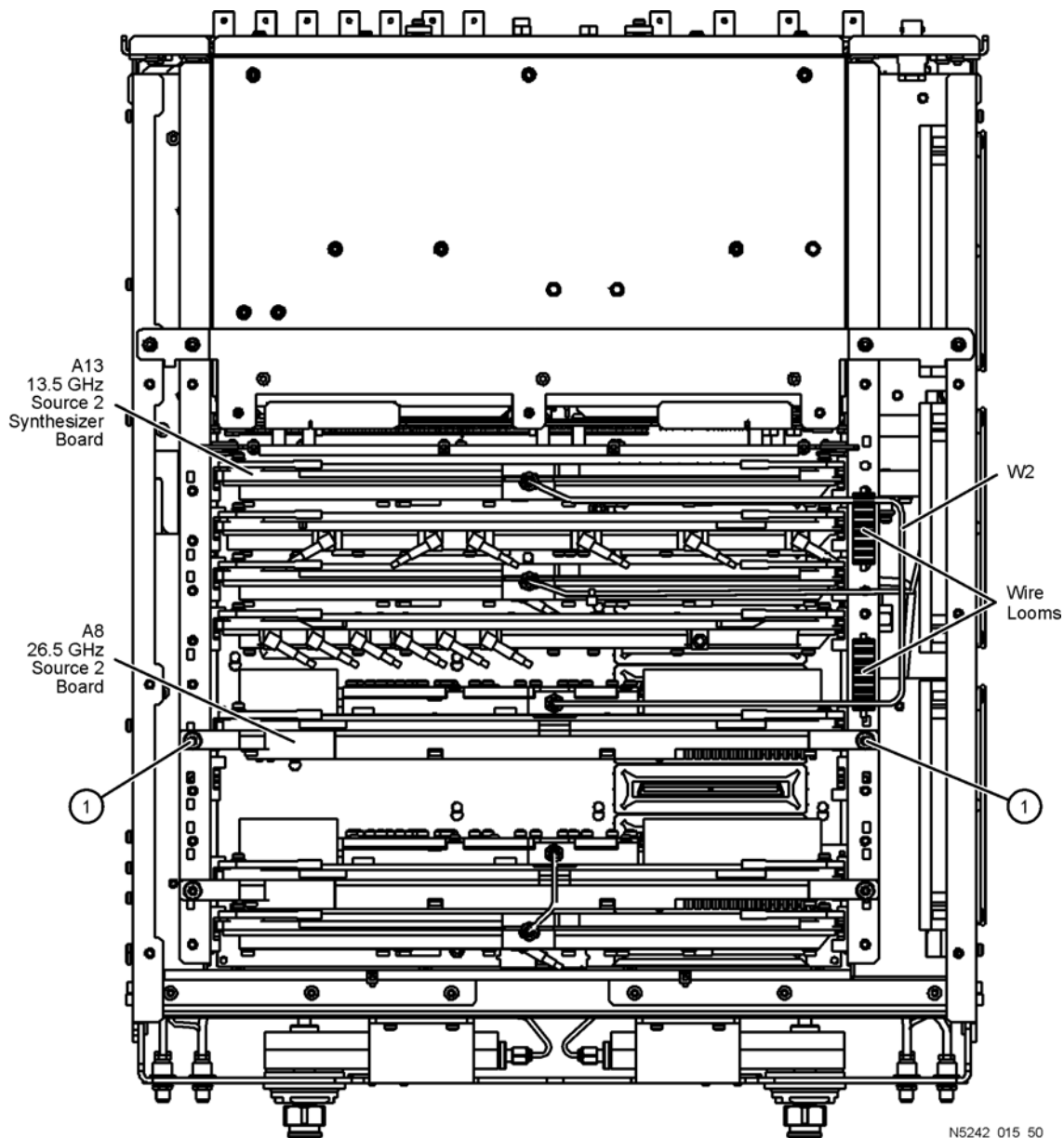

N5242_015_50

Step 16. Install the Semirigid Test Set Cables

CAUTION

Follow instructions carefully when making cable connections, especially wire harness connections. Incorrect connections can destroy components, resulting in additional customer costs.

CAUTION

Be careful not to damage the center pins of the semirigid cables. Some flexing of the cables may be necessary but do not over-bend them.

CAUTION

Use a 5/16-in torque wrench set to 10 in-lbs on all cable connections except the front and rear panel bulkhead connectors. On these, use a 9 mm nutsetter or open end torque wrench set to 21 in-lb.

To see an image showing the location of these cables, click the Chapter 6 bookmark "Bottom RF Cables, Standard 4-Port Configuration, Option 400" in the PDF Service Guide¹.

4. Install the following semirigid cables in the order listed. New parts are listed in [Table 1 on page 8](#).

- W50 (N5222-20058) REF 4 RCVR R4 IN to A24 mixer brick (R4)
- W49 (N5222-20057) REF 3 RCVR R3 IN to A24 mixer brick (R3)
- W34 (reuse) (N5242-20062) Port 2 RCVR B IN to A23 mixer brick (B)
- W26 (N5222-20034) A32 port 2 coupler to front-panel Port 2 CPLR ARM
- W33 (N5222-20055) Port 4 RCVR D IN to A24 mixer brick (D)
- W22 (N5222-20018) A31 port 4 coupler to front-panel Port 4 CPLR ARM
- W24 (N5222-20053) A32 port 2 coupler to front-panel Port 2 CPLR THRU
- W20 (N5222-20054) A31 port 4 coupler to front-panel Port 4 CPLR THRU
- W19 (N5222-20050) A27 port 4 bridge to front-panel Port 4 SOURCE OUT
- W23 (reuse) (N5242-20061) A28 port 2 bridge to front-panel Port 2 SOURCE OUT
- W27 (reuse) (N5242-20079) A28 port 2 bridge to front-panel REF 2 SOURCE OUT
 - * Secure W27 (N5242-20079) to side of deck with 2x tie wraps (1400-0249)

1. See ["Downloading the Online PNA Service Guide" on page 6](#).

Description of the Upgrade
Installation Procedure for the Upgrade

- W21 (N5222-20025) A27 port 4 bridge to front-panel REF 4 SOURCE OUT
- W32 (N5222-20048) Port 3 RCVR C IN to A24 mixer brick (C)
- W18 (N5222-20015) A30 port 3 coupler to front-panel Port 3 CPLR ARM
- W31 (reuse) (N5242-20056) Port 1 RCVR A IN to A23 mixer brick (A)
- W14 (N5222-20030) A29 port 1 coupler to front-panel Port 1 CPLR ARM
- W12 (N5222-20045) A29 port 1 coupler to front-panel Port 1 CPLR THRU
- W16 (N5222-20049) A30 port 3 coupler to front-panel Port 3 CPLR THRU
- W15 (N5222-20047) A26 port 3 bridge to front-panel Port 3 SOURCE OUT
- W17 (N5222-20023) A26 port 3 bridge to front-panel REF 3 SOURCE OUT
- W11 (reuse) (N5242-20054) A25 port 1 bridge to front-panel Port 1 SOURCE OUT

* Loosen 3x screws on A33 Reference Mixer Switch board, then slide the board to the rear of the instrument to connect the following two cables (N5242-20042 and N5242-20043).

- W36 (reuse) (N5242-20042) REF 1 RCVR R1 IN to A33 reference mixer switch
- W35 (reuse) (N5242-20043) A33 reference mixer switch to front-panel REF 1 SOURCE OUT
- * Torque 3x screws on A33 Reference Mixer Switch board to 9 in-lbs.

* Use 1/4" wrench to hold source cable connectors when tightening mating semi-rigid cables.

- W10 (reuse) (N5242-20053) W9 to A28 port 2 bridge
- W6 (N5222-20041) W5 to A26 port 3 bridge
- W8 (N5222-20042) W7 to A27 port 4 bridge
- W4 (reuse) (N5242-20050) W3 to A25 port 1 bridge
- W48 (reuse) (N5242-20076) A33 reference mixer switch to A23 mixer brick (R1)
- * Secure W48 (N5242-20076) to side of deck with 3x tie wraps (1400-0249).
- W13 (reuse) (N5242-20011) A25 port 1 bridge to A33 reference mixer switch

- W40 (reuse) (N5242-20049) REF 2 RCVR R2 IN to A23 mixer brick (R2)
- W43 (N5222-20007) A22 splitter to A23 mixer brick
* Leave the W43 loose for now.
- W44 (N5222-20008) A22 splitter to A24 mixer brick
* Leave the W44 loose for now.
- W42 (N5222-20009) A21 HMA26.5 to A22 splitter
* Leave the W42 loose for now.

* Tighten 2x screws on A22 splitter @ 9 in-lbs.
* Tighten cable nuts on W42, W43, and W44 @10 in-lbs.
- W41 (reuse) (N5242-20110) A11 13.5 GHz synthesizer to A21 HMA26.5
* Route cable through deck cutout to A11 synthesizer board.
- W60 (N5242-60013) A20 IF multiplexer (P203) to A12 SPAM (J2)
- W62 (N5242-60015) A20 IF multiplexer (P603) to A12 SPAM (J5)

Step 17.Reinstall the A19 Test Set Motherboard

CAUTION

Follow instructions carefully when making cable connections, especially wire harness connections. Incorrect connections can destroy components, resulting in additional customer costs.

1. For instructions, click the Chapter 7 bookmark “Removing and Replacing the A19 Test Set Motherboard” in the PDF Service Guide¹.
2. Connect new ribbon cable N5242-60006 from J213 to A24 mixer brick (2). To see an image showing the location of the cable, click the Chapter 6 bookmark "Bottom Ribbon Cables and Wire Harnesses, Standard 4-Port Configuration, Option 400" in the PDF Service Guide¹.

Step 18.Disassemble the 2-Port Front Panel and Assemble the 4-Port Front Panel

Before the front frame can be replaced, the items making up the back side of the front panel assembly must be removed. For instructions on removing these items, click the Chapter 7 bookmark “Removing and Replacing the A1-A3 and Other Front Panel Subassemblies” in the PDF Service Guide¹. New parts are listed in [Table 1 on page 8](#).

1. In the section “Removing the A2 USB Board,” perform step 1 (the only step).

1. See [“Downloading the Online PNA Service Guide” on page 6](#).

2. In the section “Removing the A1 Front Panel Interface Board and Keypad Assembly”, perform steps 1 - 5.
3. In the section “Removing the Power Switch Board and Power Button Keypad”, perform only steps 1 and 2.
4. Remove the braided gasket from the backside edges of the 2-port front frame and install it in the 4-port front frame (N5247-20141).
5. Rebuild the front panel assembly with the new 4-port front frame (N5247-20141) by reversing the order of the instructions previously followed.

Step 19.Reinstall the Front Panel Assembly

For instructions on reinstalling the front panel assembly, click the Chapter 7 bookmark “Removing and Replacing the Front Panel Assembly” in the PDF Service Guide¹.

In addition, attach the lower front dress panel to the test set front plate using 4x screws 0515-1227.

Step 20.Install the Front Panel Overlays

To see an image of the front panel overlay, keypad overlay, and power button overlay, click the Chapter 6 bookmark “Front Panel Assembly, Front Side, All Options” in the PDF Service Guide¹. New parts are listed in **Table 1 on page 8**.

1. Remove the protective backing from the new front panel overlay.
2. Loosely place the overlay in the recess on the front panel.
3. Placing two fingers at the middle, press the overlay firmly onto the frame while sliding your fingers in opposite directions towards the ends of the overlay. Repeat on all areas of the overlay.
4. Repeat steps 1-3 to install the keypad overlay (N5242-80005).
5. Repeat steps 1-3 to install the power button overlay (N5242-80007).
6. Repeat steps 1-3 to install the new nameplate (N5241-80001 for N5241A models or N5242-80006 for N5242A models).

Step 21.Install the Front Panel Jumper Cables

For instructions on installing the W30 front panel jumpers (N5222-20091), click the Chapter 7 bookmark “Removing and Replacing the Front Panel Assembly” in the PDF Service Guide¹.

Step 22. Position the Cables and Wires to Prevent Pinching

On the top side of the PNA, carefully position the grey flex cables so they can't be pinched between the covers and the rails.

On the bottom side of the PNA, carefully fold or push down the ribbon cables and wires so they can't be pinched between the hardware and the outer cover. Ribbon cables and wires must never be positioned on top of hardware.

Step 23.Reinstall the Inner Cover

For instructions, click the Chapter 7 bookmark "Removing the Covers" in the PDF Service Guide¹.

Step 24.Reinstall the Outer Cover

For instructions, click the Chapter 7 bookmark "Removing the Covers" in the PDF Service Guide¹

Step 25.Enable Option 400

Procedure Requirements

- The analyzer must be powered up and operating to perform this procedure.
- The Network Analyzer program must be running.
- Obtain a license key for installation of this upgrade by following the instructions on the supplied Option Entitlement Certificate.

Option Enable Procedure

1. To start the option enable utility, press UTILITY **System**, then **Service**, then **Option Enable**. An option enable dialog box will appear.
2. Click the arrow in the Select Desired Option box. A list of available options will appear.
3. In the Select Desired Option list, click P04 - 4-Ports.
4. Using the keyboard, enter the license key in the box provided. The license key is printed on the license message you received from Keysight. Enter this key exactly as it is printed on the message.
5. Click Enable.
6. Click Yes in answer to the displayed question in the Restart Analyzer? box.
7. When the installation is complete, click Exit.

Option Verification Procedure

Once the analyzer has restarted and the Network Analyzer program is again running:

1. On the analyzer's Help menu, click About Network Analyzer.
2. Verify that "400" is listed after "Options:" in the display. Click OK.

NOTE

If Option 400 has not been enabled, perform the **"Option Enable Procedure"** again. If the option is still not enabled, contact Keysight Technologies. Refer to **"Getting Assistance from Keysight" on page 4**.

Step 26. Perform Post-Upgrade Adjustments and Calibration

Adjustments

The following adjustments must be made due to the hardware changes of the analyzer.

- default EE
- source adjustment
- receiver adjustment
- receiver characterization

These adjustments are described in the PNA Service Guide and in the PNA on-line HELP. A list of equipment required to perform these adjustments is also found in the service guide.

To view this service guide information, click the Chapter 3 bookmark "Tests and Adjustments" in the PDF Service Guide¹.

After the specified adjustments have been performed, the analyzer should operate and phase lock over its entire frequency range.

Operator's Check

Perform the Operator's Check to check the basic functionality of the analyzer. For instructions, click the Chapter 3 bookmark "Tests and Adjustments" in the PDF Service Guide¹.

If you experience difficulty with the basic functioning of the analyzer, contact Keysight. Refer to **"Contacting Keysight" on page 4**.

Calibration

Although the analyzer functions, its performance relative to its specifications has not been verified. It is recommended that a full instrument calibration be performed using the analyzer's internal performance test software. To view information on the performance test software, click the Chapter 3 bookmark "Tests and Adjustments" in the PDF Service Guide¹.

1. See **"Downloading the Online PNA Service Guide" on page 6**.

Step 27. Prepare the PNA for the User

1. If necessary, reinstall front jumper cables.
2. Install the cable guards, pushing them over the front jumper cables until the cushioning material touches the front panel of the PNA.
3. Install the dust caps on the test ports.
4. Clean the analyzer, as needed, using a damp cloth.

This information is subject to change without notice.
© Keysight Technologies 2009-2015
June, 2015



N5242-90015
www.keysight.com